

L197 One Piece Reduced Port Ball Valve

- Size Range 1/4" - 2" (DN8 - DN50)
- Pressure Rating 2000 PSI
- Materials Stainless Steel, Carbon Steel
- End Connection Threaded
- Service Application Water, Oil, Gas, Thermal Fluid, Chemicals and others
- Certifications ISO 9001-2008, PED 97/23/EC
- Operation Manual

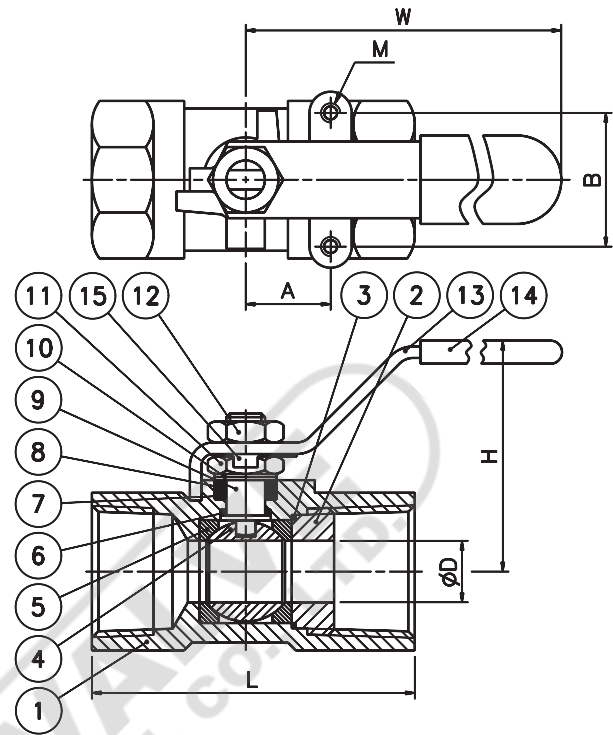

MATERIAL LIST:

ITEM	DESCRIPTION	STAINLESS STEEL	CARBON STEEL	Q'TY
1	BODY	ASTM A351 CF8M	ASTM A216 WCB	1
2	BODY INSERT	ASTM A351 CF8M/316	ASTM A216 WCB/A108	1
3	BODY GASKET	PTFE	PTFE	1
4	BALL	ASTM A351 CF8M/316	ASTM A351 CF8/304	1
5	SEAT	PTFE / R-TFE	PTFE / R-TFE	2
6	THRUST WASHER	R-TFE	R-TFE	1
7	STEM PACKING	PTFE	PTFE	1
8	GLAND	AISI 304	AISI 304	1
9	STEM	ASTM A276 316	ASTM A276 304	1
10	BELLEVILLE WASHER	AISI 301	AISI 301	2
11	GLAND NUT	AISI 304	AISI 304	1
12	HANDLE	AISI 304	ZINC PLATED STEEL	1
13	HANDLE NUT	AISI 304	AISI 304	1
14	SLEEVE	VINYL PLASTISOL	VINYL PLASTISOL	1
15	LOCK CLIP	AISI 304	AISI 304	1

P-T RATINGS

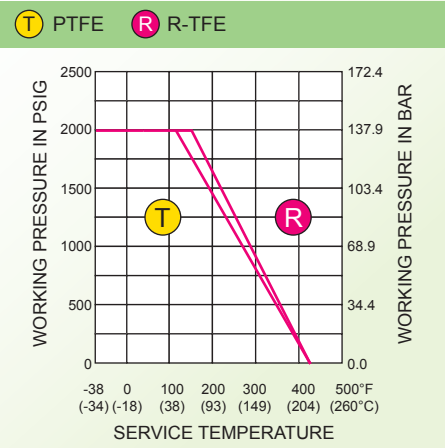

DIMENSIONS:

SIZE		ØD		L		H		W		A		B		M	Weights KG
IN	DN	IN	MM	IN	MM	IN	MM	IN	MM	IN	MM	IN	MM		
1/4"	8	0.36	9.2	2.64	67	1.81	46	4.33	110	0.50	12.7	1.12	28.5	10-24UNC	0.3
3/8"	10	0.36	9.2	2.64	67	1.81	46	4.33	110	0.50	12.7	1.12	28.5	10-24UNC	0.3
1/2"	15	0.36	9.2	2.64	67	1.81	46	4.33	110	0.50	12.7	1.12	28.5	10-24UNC	0.3
3/4"	20	0.49	12.5	2.80	71	1.97	50	4.33	110	0.50	12.7	1.12	28.5	10-24UNC	0.4
1"	25	0.63	16.0	3.31	84	2.36	60	5.51	140	0.87	22.1	1.37	34.8	10-24UNC	0.7
1 1/4"	32	0.79	20.0	3.70	94	2.56	65	5.51	140	0.87	22.1	1.37	34.8	10-24UNC	1.1
1 1/2"	40	0.96	24.5	3.94	100	2.83	72	6.30	160	0.93	23.6	1.50	38.1	1/4"-20UNC	1.3
2"	50	1.26	32.0	4.65	118	3.07	78	6.30	160	0.93	23.6	1.50	38.1	1/4"-20UNC	2.0