

# L241 Two Piece Full Port Ball Valve

Size Range 1/4" - 4" ( DN8 - DN100 )  
 Pressure Rating 1000PSI / DIN PN63  
 Materials Stainless Steel, Carbon Steel  
 End Connection Threaded  
 Service Application Water, Oil, Gas, Thermal Fluid,  
 Chemicals and others  
 Certifications ISO 9001-2008, PED 97/23/EC  
 Operation Manual

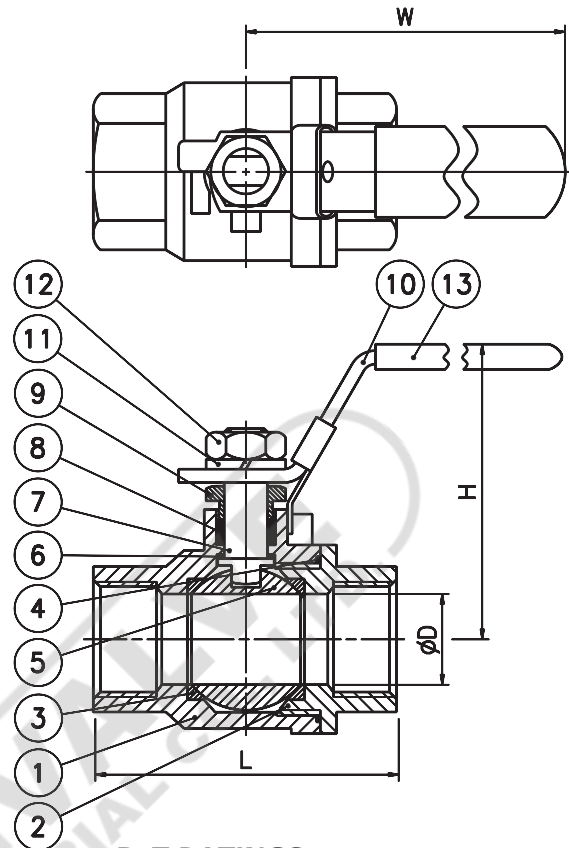

## MATERIAL LIST:

ITEM	DESCRIPTION	STAINLESS STEEL	CARBON STEEL	Q'TY
1	BODY	ASTM A351 CF8M	ASTM A216 WCB	1
2	BODY CAP	ASTM A351 CF8M	ASTM A216 WCB	1
3	SEAT	PTFE / R-TFE	PTFE / R-TFE	2
4	BODY GASKET	PTFE	PTFE	1
5	BALL	ASTM A351 CF8M/316	ASTM A351 CF8/304	1
6	THRUST WASHER	PTFE	PTFE	1
7	STEM	ASTM A276 316	ASTM A276 304	1
8	STEM PACKING	PTFE	PTFE	1-2
9	GLAND	AISI 304	AISI 304	1
10	HANDLE	AISI 304	ZINC PLATED STEEL	1
11	SPRING WASHER	AISI 304	AISI 304	1
12	HANDLE NUT	AISI 304	AISI 304	1
13	SLEEVE	VINYL PLASTISOL	VINYL PLASTISOL	1

## P-T RATINGS

T PTFE R R-TFE

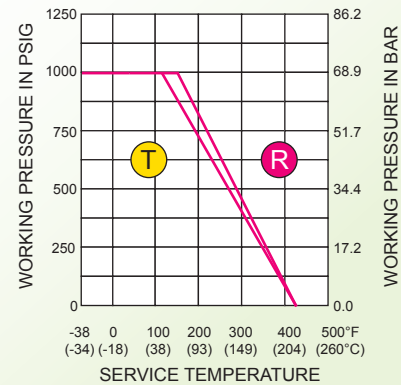

## DIMENSIONS:

SIZE		ØD		L		H		W		Weights KG
IN	DN	IN	MM	IN	MM	IN	MM	IN	MM	
1/4"	8	0.45	11.5	1.97	50	2.24	57	3.74	95	0.3
3/8"	10	0.49	12.5	2.36	60	2.24	57	3.74	95	0.3
1/2"	15	0.59	15.0	2.36	60	2.24	57	3.74	95	0.3
3/4"	20	0.79	20.0	2.72	69	2.48	63	4.13	105	0.4
1"	25	1.00	25.4	3.23	82	2.76	70	4.33	110	0.7
1 1/4"	32	1.26	32.0	3.74	95	2.95	75	5.31	135	1.1
1 1/2"	40	1.50	38.0	4.33	110	3.66	93	6.10	155	1.7
2"	50	1.97	50.0	4.88	124	3.94	100	6.10	155	2.5
2 1/2"	65	2.56	65.0	6.61	168	5.20	132	10.43	265	6.5
3"	80	3.15	80.0	7.52	191	5.63	143	10.43	265	9.8
4"	100	3.94	100.0	9.09	231	6.69	170	11.02	280	20.3