

L260 Two Piece Full Port Ball Valve

- Size Range 1/4" - 4" (DN8 - DN100)
- Pressure Rating 1000 PSI
- Materials Stainless Steel, Carbon Steel
- End Connection Threaded
- Service Application Water, Oil, Gas, Thermal Fluid, Chemicals and others
- Certifications ISO 9001-2008, PED 97/23/EC, ATEX 94/9/EC
- Operation Manual or Actuated

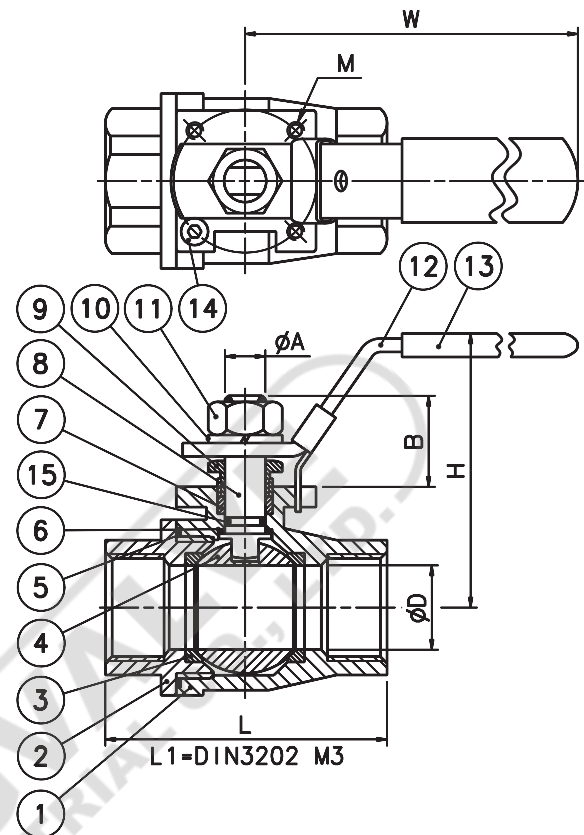

MATERIAL LIST:

ITEM	DESCRIPTION	STAINLESS STEEL	CARBON STEEL	Q'TY
1	BODY	ASTM A351 CF8M	ASTM A216 WCB	1
2	BODY CAP	ASTM A351 CF8M	ASTM A216 WCB	1
3	SEAT	PTFE / R-TFE	PTFE / R-TFE	2
4	BALL	ASTM A351 CF8M/316	ASTM A351 CF8/304	1
5	BODY GASKET	PTFE	PTFE	1
6	THRUST WASHER	PTFE	PTFE	1
7	STEM PACKING	PTFE	PTFE	1
8	STEM	ASTM A276 316	ASTM A276 304	1
9	GLAND	AISI 304	AISI 304	1
10	SPRING WASHER	AISI 304	AISI 304	1
11	HANDLE NUT	AISI 304	AISI 304	1
12	HANDLE	AISI 304	ZINC PLATED STEEL	1
13	SLEEVE	VINYL PLASTISOL	VINYL PLASTISOL	1
14	STOP PIN	AISI 304	CARBON STEEL	1
15	STEM O-RING	VITON	VITON	1

P-T RATINGS

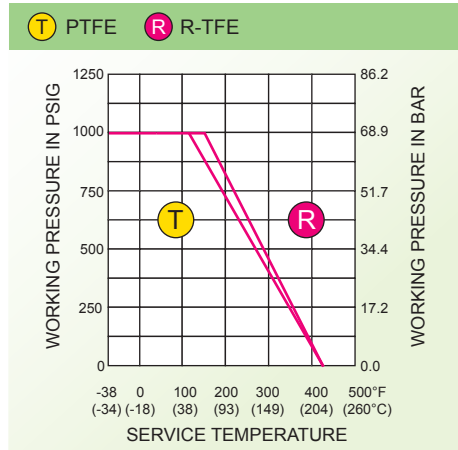

DIMENSIONS:

SIZE		ØD		L		L1		H		W		ØA		B		M	ISO 5211	Weights KG
IN	DN	IN	MM	IN	MM	IN	MM	IN	MM	IN	MM	IN	MM	IN	MM			
1/4"	8	0.43	11.0	2.32	59	2.56	65	2.13	54	5.31	135	0.31	8	0.59	15	M5	F03	0.4
3/8"	10	0.49	12.5	2.32	59	2.56	65	2.13	54	5.31	135	0.31	8	0.59	15	M5	F03	0.3
1/2"	15	0.59	15.0	2.44	62	2.95	75	2.20	56	5.31	135	0.31	8	0.67	17	M5	F03	0.4
3/4"	20	0.79	20.0	2.87	73	3.15	80	2.52	64	5.31	135	0.39	10	0.79	20	M5	F03	0.5
1"	25	1.00	25.4	3.35	85	3.54	90	2.68	68	6.50	165	0.47	12	0.98	25	M5	F04	0.9
1 1/4"	32	1.26	32.0	3.82	97	4.33	110	2.91	74	6.50	165	0.47	12	0.98	25	M5	F04	1.8
1 1/2"	40	1.50	38.0	4.53	115	4.72	120	3.54	90	6.89	175	0.55	14	0.98	25	M6	F05	2.0
2"	50	1.97	50.0	5.28	134	5.51	140	3.94	100	6.89	175	0.55	14	0.98	25	M6	F05	3.4
2 1/2"	65	2.56	65.0	6.61	168	7.28	185	5.39	137	10.24	260	0.75	19	1.57	40	M8	F07	6.5
3"	80	3.15	80.0	7.52	191	8.07	205	5.79	147	10.24	260	0.75	19	1.57	40	M8	F07	9.7
4"	100	3.94	100.0	9.09	231	9.45	240	6.93	176	11.02	280	0.98	25	1.81	46	M10	F10	20.3