

# L600 Flanged Full Port Ball Valve

Size Range 1/2" - 4" ( DN15 - DN100 )  
 Pressure Rating ANSI Class150  
 Materials Stainless Steel, Carbon Steel  
 Service Application Water, Oil, Gas, Thermal Fluid,  
 Chemicals and others  
 Certifications ISO 9001, PED 97/23/EC  
 Operation Manual or Actuated

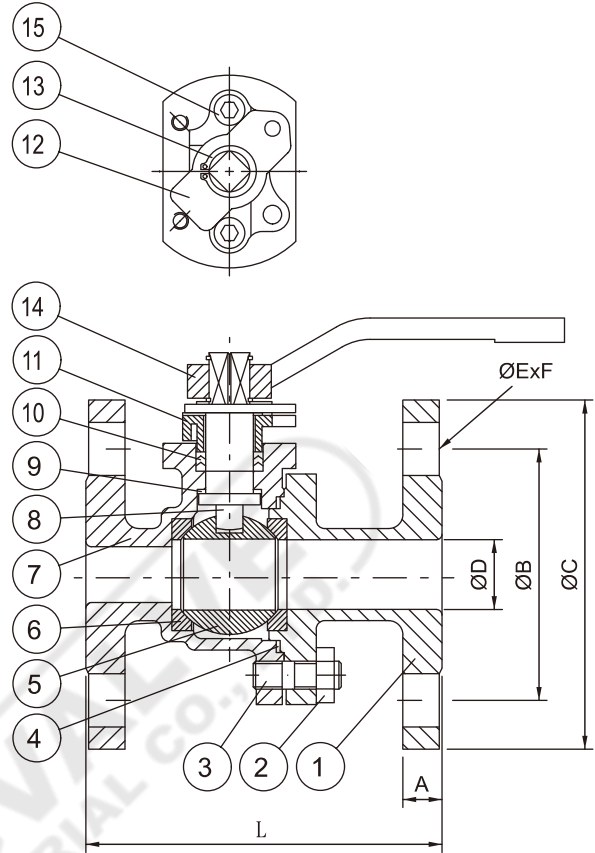

## MATERIAL LIST:

ITEM	DESCRIPTION	STAINLESS STEEL	CARBON STEEL	Q'TY
1	BODY CAP	ASTM A351 CF8	ASTM A216 WCB	1
2	BODY NUT	AISI 304	CARBON STEEL	4-12
3	BODY BOLT	AISI 304	CARBON STEEL	4-12
4	BODY GASKET	PTFE	PTFE	1
5	BALL	ASTM A351 CF8M/316	ASTM A315 CF8/304	1
6	SEAT	PTFE	PTFE	2
7	BODY	ASTM A351 CF8	ASTM A216 WCB	1
8	STEM	ASTM A276 316	ASTM A276 304	1
9	THRUST WASHER	PTFE	PTFE	1
10	STEM PACKING	PTFE	PTFE	1-2
11	GALND	ASTM A351 CF8	ASTM A351 CF8	1
12	LOCK CLIP	AISI 304	AISI 304	1
13	STEM RETAINING RING	AISI 420	AISI 420	1
14	HANDLE	FCD 45	FCD 45	1
15	GLAND BOLT	AISI 304	AISI 304	2

## P-T RATINGS

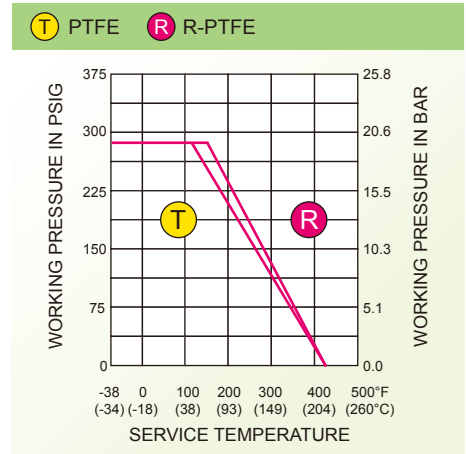

## DIMENSIONS:

SIZE		ØD		L		A		ØB		ØC		ØE		F	Weights KG
IN	DN	IN	MM	IN	MM	IN	MM	IN	MM	IN	MM	IN	MM		
1/2"	15	0.50	12.7	4.25	108	0.44	11.2	2.38	60.5	3.50	88.9	0.62	15.8	4	2.0
3/4"	20	0.75	19.1	4.62	117	0.44	11.2	2.75	69.9	3.88	98.6	0.62	15.8	4	2.2
1"	25	1.00	25.4	5.00	127	0.44	11.2	3.13	79.2	4.25	108.0	0.62	15.8	4	3.1
1 1/2"	40	1.50	38.1	6.50	165	0.56	14.2	3.88	98.6	5.00	127.0	0.62	15.8	4	6.4
2"	50	2.00	50.8	7.00	178	0.62	15.8	4.75	120.7	6.00	152.4	0.75	19.1	4	8.2
2 1/2"	65	2.50	63.5	7.50	191	0.69	17.5	5.50	139.7	7.00	177.8	0.75	19.1	4	14.4
3"	80	3.00	76.2	8.00	203	0.75	19.1	6.00	152.4	7.50	190.5	0.75	19.1	4	19.1
4"	100	4.00	101.6	9.00	229	0.94	23.9	7.50	190.5	9.00	228.6	0.75	19.1	8	29.1