

L630 Flanged Full Port Ball Valve

Size Range 1/2"-4" (DN15 - DN100)
 Pressure Rating JIS 10K
 Materials Stainless Steel, Carbon Steel
 End Connection Flanged JIS 10K
 Service Application Water, Oil, Gas, Thermal Fluid,
 Chemicals and others
 Certifications ISO 9001-2008, PED 97/23/EC
 Operation Manual or Actuated

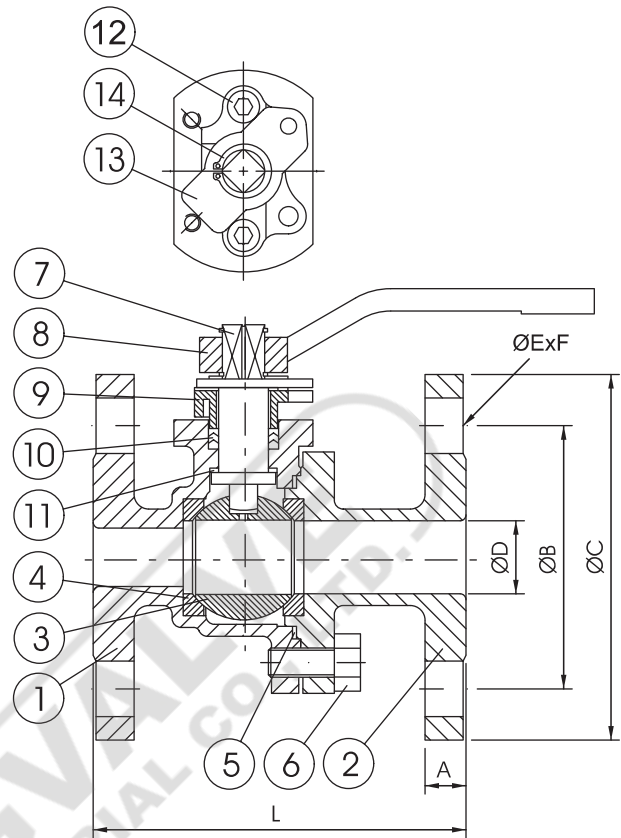

MATERIAL LIST:

ITEM	DESCRIPTION	STAINLESS STEEL	STAINLESS STEEL	Q'TY
1	BODY	JIS G5121 SCS14A	JIS G5121 SCS13A	1
2	BODY CAP	JIS G5121 SCS14A	JIS G5121 SCS13A	1
3	BALL	ASTM A351 CF8M/316	ASTM A351 CF8/304	1
4	SEAT	PTFE / R-TFE	PTFE / R-TFE	2
5	BODY GASKET	PTFE	PTFE	1
6	BODY BOLT	AISI 304	CARBON STEEL	4-8
7	STEM	ASTM A276 316	ASTM A276 304	1
8	HANDLE	FCD45	FCD45	1
9	GLAND	ASTM A351 CF8	ASTM A351 CF8	1
10	STEM PACKING	PTFE	PTFE	3-4
11	THRUST WASHER	PTFE	PTFE	1
12	GLAND BOLT	AISI 304	AISI 304	2
13	LOCK CLIP	AISI 304	AISI 304	1
14	STEM RETAINING RING	AISI 420	AISI 420	1

P-T RATINGS

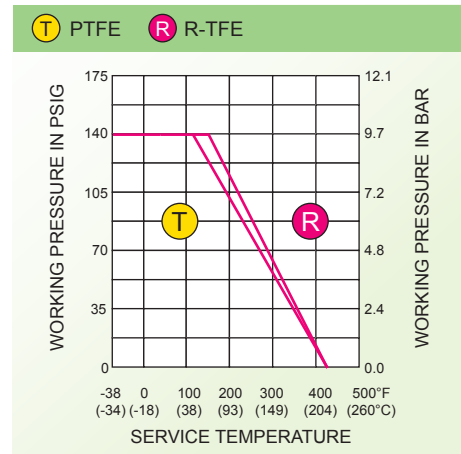

DIMENSIONS:

SIZE		ØD		L		A		ØB		ØC		ØE		F	Weights KG
IN	DN	IN	MM	IN	MM	IN	MM	IN	MM	IN	MM	IN	MM		
1/2"	15	0.59	15	4.25	108	0.47	12	2.76	70	3.74	95	0.59	15	4	2.5
3/4"	20	0.79	20	4.61	117	0.55	14	2.95	75	3.94	100	0.59	15	4	2.9
1"	25	0.98	25	5.00	127	0.55	14	3.54	90	4.92	125	0.74	19	4	4.2
1 1/4"	32	1.26	32	5.51	140	0.63	16	3.94	100	5.31	135	0.74	19	4	5.0
1 1/2"	40	1.57	38	6.50	165	0.63	16	4.13	105	5.51	140	0.74	19	4	7.0
2"	50	1.97	50	7.01	178	0.63	16	4.72	120	6.10	155	0.74	19	4	8.7
2 1/2"	65	2.56	65	7.48	190	0.71	18	5.51	140	6.89	175	0.74	19	4	14.0
3"	80	3.15	80	7.99	203	0.71	18	5.91	150	7.28	185	0.74	19	8	17.7
4"	100	3.94	100	9.02	229	0.71	18	6.89	175	8.27	210	0.74	19	8	24.7