

L640 Flanged Full Port Ball Valve

Size Range 1/2" - 4" (DN15 - DN100)

Pressure Rating DIN PN40

Materials Stainless Steel, Carbon Steel

Service Application Water, Oil, Gas, Thermal Fluid,
Chemicals and others

Certifications ISO 9001, PED 97/23/EC

Operation Manual or Actuated

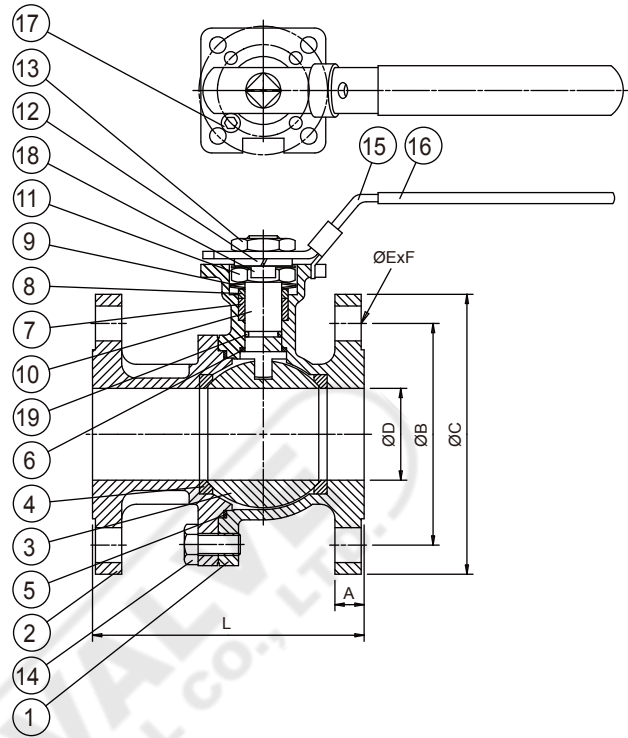

MATERIAL LIST:

ITEM	DESCRIPTION	STAINLESS STEEL	CARBON STEEL	Q'TY
1	BODY	EN10213-4 DIN1, 4408	EN0213 DIN1, 0619	1
2	BODY CAP	EN10213-4 DIN1, 4408	EN0213 DIN1, 0619	1
3	BALL	EN10213-4 DIN1, 4408	EN10213-4 DIN1, 4408	1
4	SEAT	PTFE	PTFE	2
5	BODY GASKET	PTFE	PTFE	1
6	THRUST WASHER	PTFE	PTFE	1
7	STEM PACKING	PTFE	PTFE	1-3
8	GLAND	AISI 304	AISI 304	1
9	BELLEVILLE WASHER	AISI 301	AISI 301	2
10	STEM	EN10213-4 DIN1, 4401	EN10213-4 DIN1, 4301	1
11	GLAND NUT	AISI 304	AISI 304	1
12	SPRING WASHER	AISI 304	AISI 304	1
13	HANDLE NUT	AISI 304	AISI 304	1
14	BODY BOLT	AISI 304	CARBON STEEL	4-8
15	HANDLE	AISI 304	ZINC PLATED STEEL	1
16	SLEEVE	VINYL PLASTISOL	VINYL PLASTISOL	1
17	STOP PIN	AISI 304	CARBON STEEL	1
18	LOCK CLIP	AISI 304	AISI 304	1
19	STEM O-RING	VITON	VITON	1

P-T RATINGS

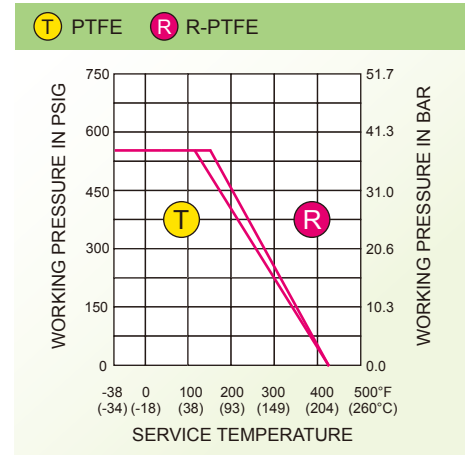

DIMENSIONS:

SIZE		ØD		L		A		ØB		ØC		ØE		F	ISO 5211	Weights KG
IN	DN	IN	MM	IN	MM	IN	MM	IN	MM	IN	MM	IN	MM			
1/2"	15	0.59	15	4.53	115	0.63	16	2.56	65	3.75	95	0.55	14	4	F03-F04	2.3
3/4"	20	0.79	20	4.72	120	0.71	18	2.95	75	4.13	105	0.55	14	4	F03-F04	3.0
1"	25	1.98	25	4.92	125	0.71	18	3.47	85	4.53	115	0.55	14	4	F04-F05	4.3
1 1/4"	32	1.26	32	5.12	130	0.71	18	3.94	100	5.51	140	0.71	18	4	F04-F05	4.5
1 1/2"	40	1.57	40	5.52	140	0.71	18	4.33	110	5.91	150	0.71	18	4	F05-F07	7.3
2"	50	1.97	50	5.91	150	0.79	20	4.92	125	6.50	165	0.71	18	4	F05-F07	9.1
2 1/2"	65	2.52	65	6.69	170	0.87	22	5.71	145	7.28	185	0.71	18	8	F07-F10	15.1
3"	80	2.99	76	7.09	180	0.94	24	6.30	160	7.87	200	0.71	18	8	F07-F10	18.8
4"	100	3.94	100	7.48	190	0.94	24	7.48	190	9.25	235	0.87	22	8	F10-F12	35.0