

# Fire Safe API607 & ISO10497 L660F Wafer Type Full Port Ball Valve

Size Range 1/2" - 4" ( DN15 - DN100 )  
 Pressure Rating DIN PN16  
 Materials Stainless Steel, Carbon Steel  
 Service Application Water, Oil, Gas, Thermal Fluid,  
 Chemicals and others  
 Certifications ISO 9001-2008, PED 97/23/EC,  
 ATEX 94/9/EC, TA - Luft 2002,  
 API 607 5th & ISO 10497  
 Operation Manual or Actuated

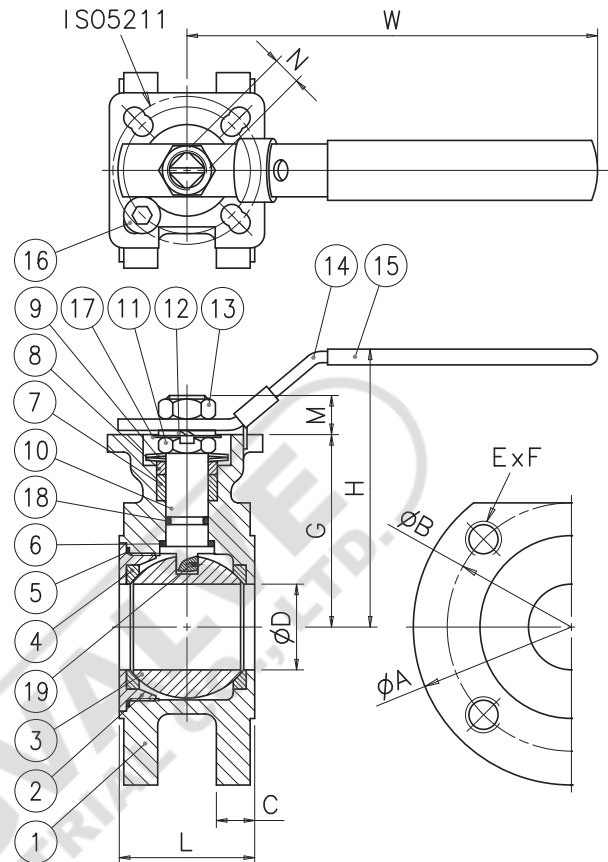

## MATERIAL LIST:

ITEM	DESCRIPTION	STAINLESS STEEL	CARBON STEEL	Q'TY
1	BODY	EN10213-4 1.4408	EN10213-2 1.0619	1
2	BODY CAP	EN10213-4 1.4408	EN10213-2 1.0619	1
3	BALL	EN10213-4 1.4408	EN10213-4 1.4308	1
4	SEAT	PTFE / R-TFE	PTFE / R-TFE	2
5-1	BODY GASKET	PTFE	PTFE	1
5-2		GRAPHITE	GRAPHITE	1
6-1	THRUST WASHER	PTFE	PTFE	1
6-2		GRAPHITE	GRAPHITE	1
7	STEM PACKING	GRAPHITE	GRAPHITE	1-2
8	GLAND	AISI 304	AISI 304	1
9	BELLEVILLE WASHER	AISI 301	AISI 301	2
10	STEM	EN10213-4 1.4401	EN10213-4 1.4301	1
11	GLAND NUT	AISI 304	AISI 304	1
12	SPRING WASHER	AISI 304	AISI 304	1
13	HANDLE NUT	AISI 304	AISI 304	1
14	HANDLE	AISI 304	ZINC PLATED STEEL	1
15	SLEEVE	VINYL PLASTISOL	VINYL PLASTISOL	1
16	STOP PIN	AISI 304	CARBON STEEL	1
17	LOCK CLIP	AISI 304	AISI 304	1
18	STEM O-RING	VITON	VITON	1
19	ANTI-STATIC DEVICE	AISI 316	AISI 316	1

## P-T RATINGS

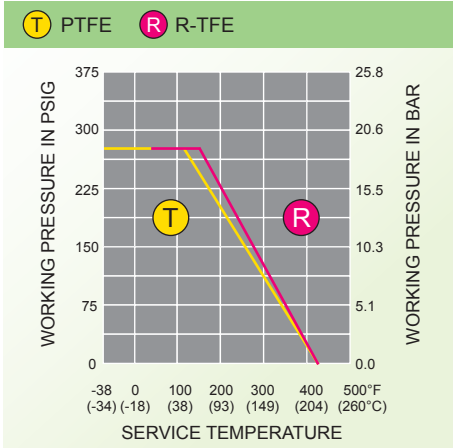

## DIMENSIONS:

SIZE		ØD		L		ØA		ØB		C		E	F	G		M		N		H		W		ISO5211	Weight KG
IN	DN	IN	MM	IN	MM	IN	MM	IN	MM	IN	MM			IN	MM	IN	MM	IN	MM	IN	MM	IN	MM		
1/2"	15	0.59	15	2.05	52	3.74	95	2.56	65	0.55	14	4	M12	1.93	49	0.35	9	0.35	9	3.46	88	5.31	135	F03-F04	1.6
3/4"	20	0.79	20	2.05	52	4.13	105	2.95	75	0.63	16	4	M12	2.13	54	0.35	9	0.35	9	3.66	93	5.31	135	F03-F04	2.1
1"	25	1.00	25	2.36	60	4.53	115	3.35	85	0.63	16	4	M12	2.32	59	0.47	12	0.43	11	3.86	98	6.50	165	F04-F05	2.8
1 1/4"	32	1.26	32	2.28	58	5.51	140	3.94	100	0.71	18	4	M16	2.48	63	0.47	12	0.43	11	3.98	101	6.50	165	F04-F05	3.0
1 1/2"	40	1.50	38	3.07	78	5.91	150	4.33	110	0.71	18	4	M16	3.03	77	0.63	16	0.55	14	4.57	116	7.68	195	F05-F07	5.3
2"	50	1.97	50	3.15	80	6.50	165	4.92	125	0.79	20	4	M16	3.35	85	0.63	16	0.55	14	4.88	124	7.68	195	F05-F07	6.9
2 1/2"	65	2.56	65	4.33	110	7.28	185	5.71	145	0.71	20	4	M16	4.13	105	0.75	19	0.67	17	5.98	152	11.81	300	F07	11.6
3"	80	2.99	76	4.76	121	7.87	200	6.30	160	0.79	20	8	M16	4.45	113	0.75	19	0.67	17	6.34	161	11.81	300	F07	14.5
4"	100	3.78	96	5.83	148	8.66	220	7.09	180	0.87	22	8	M16	5.28	134	0.94	24	0.87	22	7.48	190	13.19	335	F07-F10	21.0
6"	150	4.92	125	7.60	192	11.22	285	9.45	240	0.87	22	8	M20	6.85	174	1.06	27	1.06	27	9.84	250	23.62	600	F10-F12	45.0